



# Valve Regulated Lead-Acid Rechargeable Battery



## EVP7-12

The battery is constructed by plates, separators, safety valves and container. Since the electrolyte is held by a glass-mat separator and plates, the battery can be used in any direction and position without leakage.

### PERFORMANCE SPECIFICATIONS

Nominal Voltage(V).....	12 volts(6cells in series)
Nominal Capacity(Ah)	
20 Hour rate F.V.(1.75V/cell) (0.35A to 10.50volts) .....	7.00Ah
5 Hour rate F.V.(1.75V/cell) (1.19A to 10.50volts) .....	5.95Ah
30 Min rate F.V.(1.30V/cell) (8.75A to 7.80volts) .....	4.37Ah
Approximate Weight .....	2750g(6.06lbs.)
Terminal	
Standard.....	Type T2
Optional.....	Type T1
Internal Resistance (Fully Charged Battery).....	<15mΩ
Maximum Discharge Current For 5 sec.(A).....	105A
Maximum Charge Current(A).....	2.1A
Ambient Temperature	
Charge.....	0°C(32°F)~40°C(104°F)
Discharge.....	-20°C(-4°F)~50°C(122°F)
Storage.....	-20°C(-4°F)~40°C(104°F)
Vibration test:	
Frequency: 16.7Hz	
Amplitude: 4mm	
Vibrate the battery horizontally or vertically for 60 minutes. The battery have no abnormality.	
Case.....	ABS
Dimension(mm/inch)	
Length           ±1.5mm.....	151/5.94
Width           ±1.5mm.....	65/2.56
Container Height ±1.5mm.....	94/3.70
Total Height   ±2mm.....	100/3.94
Application.....	Laboratory Equipment, Toy-Cars, Power Packs, Fishing Lights.

## EVP7-12 Battery discharge characteristics (25 °C/77 °F)

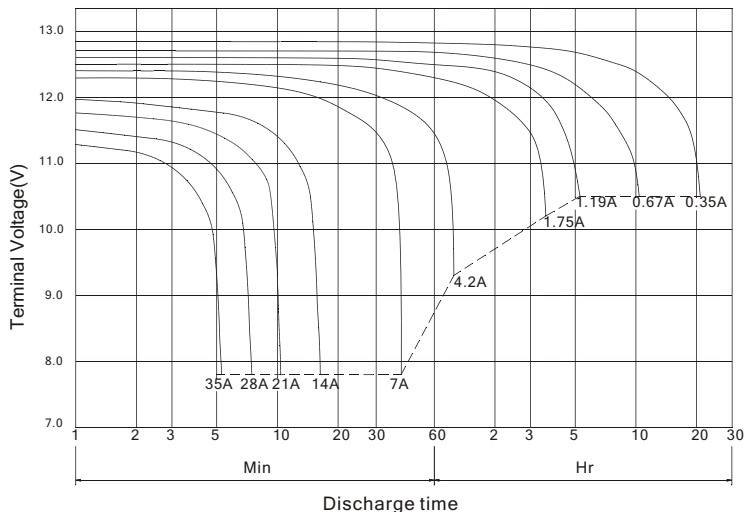

## Battery Charging Characteristics

(Typical example of the charge characteristics for the cycle use)

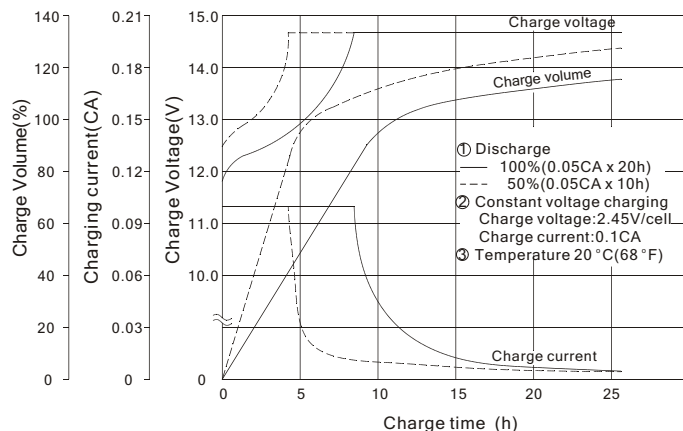

## Charging Procedure

Application	Charging method	Charging Voltage at 20 °C (V/cell)	Temperature compensation coefficient of charging voltage (mV/°C/cell)	Max. charging current (CA)	Charging time 0.1CA, 20 °C (h)		Temp (°C)
					100% discharge	50% discharge	
For standby power Source	Constant voltage & Constant current charging	2.25~2.30	-3	0.3	24	20	0~40 (32~104°F)
For cycle service	(with current restriction)	2.40~2.50	-4	0.3	16	10	

## Battery Life Characteristics of Cyclic Use

Testing Conditions : Discharge Current : 1C Amp (F.V. 1.60V/cell)

Charging Current : 0.1C Amp

Charging Volume : 120% OF Discharge Capacity

Ambient Temperature : 20 °C (68 °F)

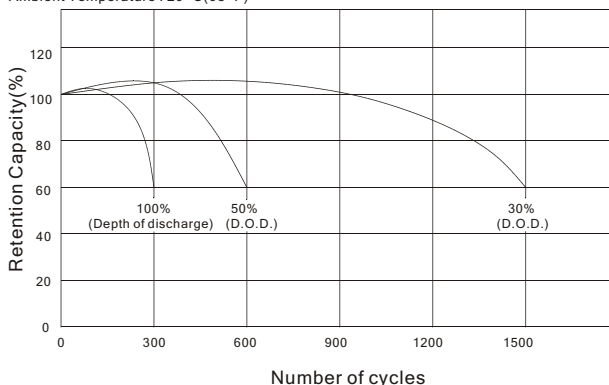

## OUTER DIMENSIONS

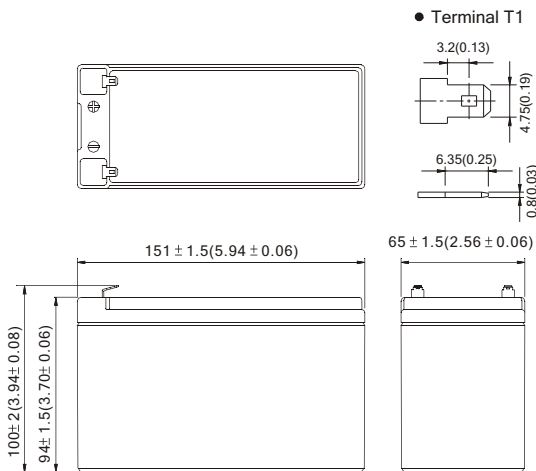

## TERMINAL TYPE

mm (inch)

## Constant power discharge characteristics at 25°C/77°F

Final Voltage	Discharge time								
	5Min	10Min	15Min	30Min	45Min	1Hr	3Hr	5Hr	10Hr
10.80V	301	213	161	96.3	68.1	54.9	22.3	14.1	7.8
10.50V	348	231	169	99.9	71.0	56.5	22.8	14.3	8.0
10.20V	370	240	174	102	72.4	57.8	23.0	14.4	8.1
9.90V	387	245	178	104	73.3	58.4	23.2	14.5	8.1
9.60V	399	250	181	105	74.1	58.9	23.3	14.5	8.1

## TERMINAL POSITION

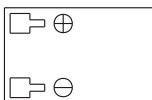

**B.B. BATTERY CO., LTD.**

Web Site: <http://www.bb-battery.com>

**USA:**  
B&B BATTERY(USA) INC.  
6415 RANDOLPH ST.COMMERCE,  
CA,90040 U.S.A.  
TEL:1-323-278-1900.1-800-278-8599  
FAX:1-323-278-1268  
E-Mail:sales@bb-battery.com

**EUROPE:**  
B&B BATTERY(EUROPE) B.V.  
3 WIJNGAARDVELD, 9300 AALST,BELGIUM  
TEL:(00)32-53781567  
FAX:(00)32-53781567  
E-Mail:hansdevriese@bb-battery.com

**CHINA FACTORY:**  
B.B. BATTERY CO., LTD.  
CHENG DONG TRIAL AREA,HUANG GANG,  
RAOPING, GUANG DONG,CHINA,515700  
TEL:86-768-7601001-2  
FAX:86-768-7601469  
E-Mail:maggy@bb-battery.com

**HONG KONG:**  
NATIONAL TRADING LTD.  
TEL:852-2301-3800  
FAX:852-2739-1182  
E-Mail:bbhk@hkstar.com

**JAPAN:**  
B&B BATTERY(JAPAN) CO., LTD.  
1375-11 NARAHARA-MACHI,HACHIOJI,  
TOKYO 193-0803,JAPAN.  
TEL:81-426-25-6375  
FAX:81-426-25-6375  
E-Mail:miyata@bb-battery.com

**TAIWAN:**  
B.B. BATTERY(TAIWAN) CO., LTD.  
TEL:886-6-502-5150  
FAX:886-6-589-8087  
E-Mail:maggy@bb-battery.com

